

THIS COPY IS PROVIDED ON A RESTRICTED BASIS AND IS NOT TO BE USED IN ANY WAY DETRIMENTAL TO THE INTERESTS OF PANDUIT CORP.

PANDUIT P/N	WEIGHT
CHLS2S**-X	.17 LB/10 PCS (76.2 g/10 PCS)

NOTES:

- SEE CURRENT CATALOG FOR ADDITIONAL PART NUMBER SUFFIXES TO INDICATE COLOR AND OR PACKAGE QUANTITY.
- SEE CATALOG FOR COMPLETE LIST OF PARTS APPLICABLE FOR USE WITH THIS PART.
- DIMENSIONS IN () ARE IN METRIC.
- PART INCLUDES:
 - 1- HOUSING
 - 2- SHUTTERS (INSTALLED)
 - 1- LABEL
 - 1- LABEL COVER

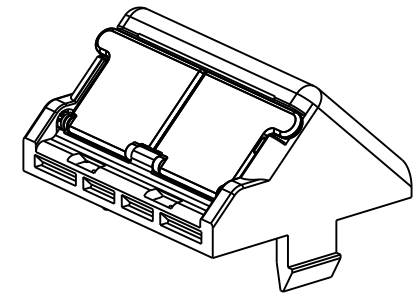
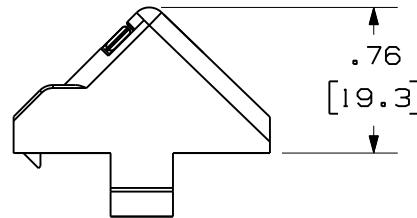
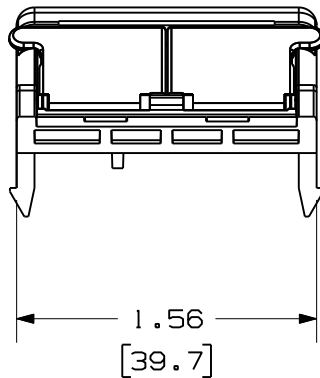
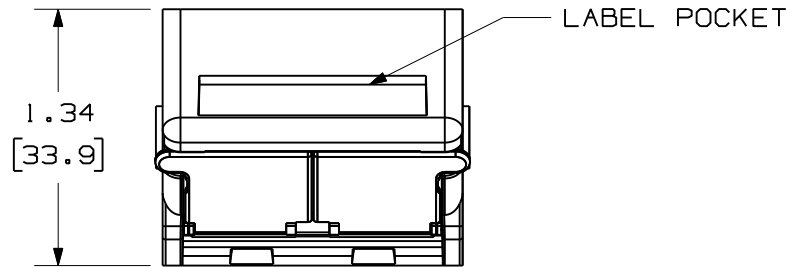

MODEL FILENAME	10M159AA/00	SIZE	A
DRAWING FILENAME	10M159AA_DA/00A		
MINI-COM 2 POSITION SLOPED SHUTTER INSERT WITH LABEL CUSTOMER DRAWING			
	PANDUIT ™ CORP. TINLEY PARK, ILL 60477	I.I. NUMBER	N/A
ALL DIMENSIONS ARE GIVEN IN INCHES, UNLESS OTHERWISE SPECIFIED. DIMENSIONAL TOLERANCES ARE: (.X) ± .010(.3) (.XX) ± .031(.8) ANGLES ±		PRODUCT SPEC	N/A
		WORK INSTRUCTION	N/A
	THIRD ANGLE PROJECTION	SCALE	NONE
DRAWN BY	JsP	MATERIAL:	ABS
DATE	2-11-10	PART NO.	CHLS2S**-X
CHK'D		DRAWING NO.	10M159AA-01

REV	DATE	BY	CHK	DESCRIPTION	ECN	R	CUST	SUP	OTH
R	2-11-10	JsP		RELEASED TO PRODUCTION	10M159AA-01				